

C&D Zodiac

Leveraging knowledge corporate-wide with DS PLM



Overview



C&D ZODIAC

C&D Zodiac is a leading global designer and manufacturer of aircraft interiors, including sidewall and ceiling panels, storage bins, seats, lavatories and galleys. C&D has developed numerous specialized materials optimized for the high-stress, low-weight demands of aircraft and takes pride in the role its interiors play in creating airline identity and enhancing brand value.

Like most aerospace suppliers, C&D traditionally invested large sums in product development and recouped the costs over the life of an aircraft model. But today, airlines and their OEM partners are imposing highly competitive pricing structures. This creates intense pressure on suppliers to minimize upfront investments in product development.

To meet this challenge, C&D has focused on lean product development, eliminating the bottlenecks and errors that create waste and drive up development costs. C&D has also worked to empower all of its employees with access to information, allowing them to positively influence the development of designs early in the process.

"It's in our best interest to do what we can to make our customers healthy because we need them to stay in business," says C&D IT Director Jon Ripley. "We see DS PLM as a critical piece in this puzzle."

Improved data access for improved productivity

To meet the demands of OEM and airline pricing structures without sacrificing product innovation or quality, C&D Aerospace is optimizing its investment in DS PLM from Dassault Systèmes.

■ Challenge

Identify and eliminate bottlenecks and hidden costs to minimize product development costs and support a highly competitive pricing structure.

■ Solution

DS PLM enabled major improvements in productivity, leveraging a centralized database to capture and re-use knowledge.

■ Benefits

Reduced design costs and integrated manufacturing have contributed to improved profitability and design flexibility for superior customer value.



"With the visibility DS PLM gives us, our products reflect not only our engineering abilities, but the knowledge and experience of our entire company."

Mike McCarthy, Vice President of Technical Operations, C&D Zodiac



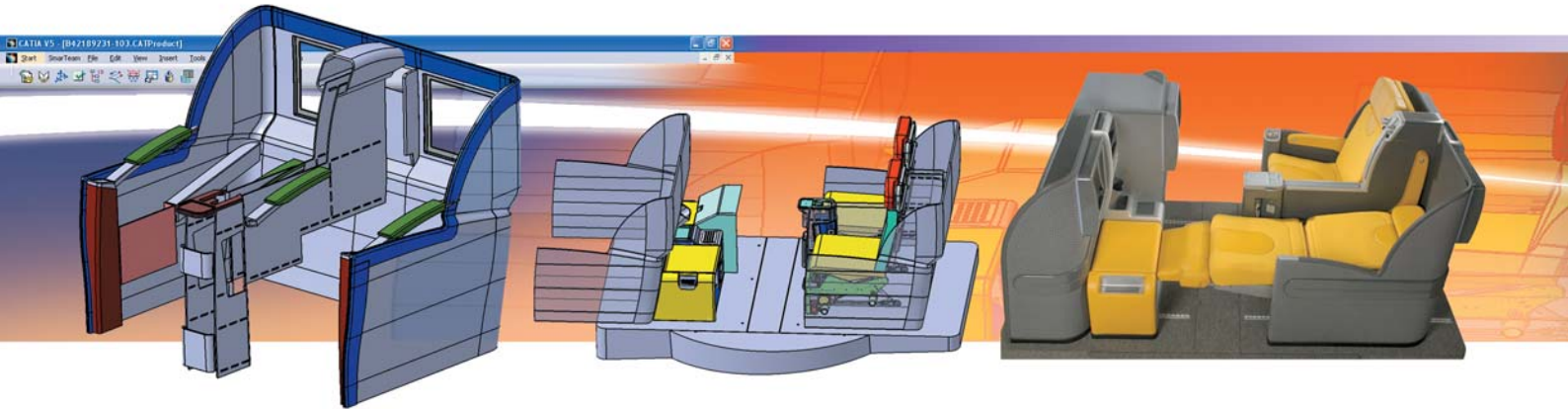

“You don’t want late notification from production that an engineering decision is creating problems. With DS PLM we get that information much sooner.”

Brett Fontaine, Engineering Systems Manager, C&D Zodiac

C&D realized major improvements in productivity as it applied CATIA V5 to its new aircraft programs. In V4, every engineer maintained personal directories of design files, leading to duplication and increasing the risk of error. V5 eliminates these challenges with a centralized 3D database shared by all. Because CATIA V5 is Windows-based, it also eliminated the need for engineers to have two separate workstations on their desks, and simplified information sharing with other departments.

CATIA V5 also features Knowledgeware, which allows C&D to capture each designer’s best practices and standardize them across the company. Relational design capabilities allow C&D to build standardized design templates of “smart parts” that can be quickly modified in hours instead of weeks, simply by entering new parameters.

ENOVIA SmarTeam, meanwhile, structures all of the company’s design data, making information easy to locate and ensuring that everyone works with the latest revisions. ENOVIA SmarTeam also maintains the relationships among various parts, automatically applying the rules and templates that make parts “smart.”

ENOVIA SmarTeam also facilitates data sharing among C&D’s offices in the US, Canada, Mexico, Brazil and France. This allows the company to take advantage of each office’s specialized skills to improve resource utilization.

Efficient processes enhance profitability

C&D Zodiac’s innovative application of DS PLM to the challenges of lean product development has generated a wide variety of benefits, including improved productivity. “More than 95 percent of our revenue is from manufactured parts,” says Mike McCarthy, Vice President of Technical Operations. “DS PLM is helping us to take our product data and turn it into parts in the most efficient manner.”

By allowing all of the company’s experts to simultaneously see designs as they develop, ENOVIA SmarTeam helps C&D take advantage of their knowledge. Purchasing, for example, can recommend the most cost-effective part selections, while Manufacturing can advise on manufacturability or suggest tooling improvements. By identifying issues early, when there is still time to change the design, C&D optimizes cost and quality.



In a pilot project for the Airbus A340s overhead stowage bins, for example, C&D output 3D CATIA V5 design data directly to the routers in its machine shop, eliminating a time-consuming data translation step. “The idea is that we will now take that knowledge and implement it through the remainder of the company and its programs,” McCarthy says. ENOVIA SmarTeam helps C&D ensure that data released to manufacturing is mature and reliable.

C&D has traditionally co-located its facilities near its customers, allowing each office to specialize in the areas most important to its specific client. With DS PLM, improved collaboration capabilities facilitate allocating workload more evenly, eliminating the need to physically reassign people from one office to another.

To add value to its design work, C&D’s goal is to maximize the flexibility of each design to give airline customers more options for changes throughout the life of an aircraft. “CATIA V5 gives us the power to imagine what the maximums are that each airline might want 5-10 years down the road and create a design today that will allow for those options more economically in the future,” says Brett Fontaine, Engineering Systems Manager.

Accommodating late-cycle design changes affordably

Outfitting corporate jets has always been a challenge because customers are likely to change their minds about the features they want late in the game, but are unwilling to accept delivery delays. “Knowledgware is helping us accommodate those situations because we can change a few attributes and the design adjusts automatically,” says Jon Ripley, IT Director. “We can produce drawings in hours instead of weeks. It’s working so well with private jets, we’re beginning to apply it to every project.”

DS PLM also contributes to job satisfaction at C&D. “Engineers’ favorite activity is not reconfiguring, it’s designing,” Ripley says. So C&D has created a catalog of “smart parts” in ENOVIA SmarTeam that engineers can build into their designs. When parameters change, the smart parts reconfigure the design automatically to accommodate them. “When we showed this catalog to the team, it was an easy sell to get them to give up their own directories,” he says.

Adds Fontaine: “The response is always, ‘When can we have more?’ Knowledgware brings automation to every designer’s hands so we can capture how we do things.”



“Every engineer has something they do very well. The key is to use DS PLM to capture that and replicate it across the entire organization.”

Jon Ripley, IT Director, C&D Zodiac

To add even more value to its design work, C&D's goal is to maximize the flexibility of each design to give airline customers more options for changes throughout the life of an aircraft. "CATIA V5 gives us the power to imagine what the maximums are that each airline might want 10 years down the road and create a design today that will allow for those options more economically in the future," Fontaine says.

Extending the benefits with workflow and integration

C&D's next priority is to implement ENOVIA SmarTeam Workflow capabilities, defining and digitizing the company's processes so they can be carried out electronically rather than on paper. "Workflow will let us see where the bottlenecks are and eliminate them, reducing scrap, machine changes and all the other waste that drives up costs," Fontaine says.

C&D also plans to focus on integrating ENOVIA SmarTeam data with the enterprise application that stores the company's business data, giving its engineers the ability to view the cost of design alternatives while providing top executives with a better dashboard for decision making. "To succeed in

business today you need smarter data, data that can be easily viewed and leveraged broadly," McCarthy says. "We believe DS PLM is critical to helping us accomplish that."

Focus on RAND

Rand North America, Inc, a subsidiary of Dassault Systèmes, markets and sells product lifecycle management (PLM) software solutions from Dassault Systèmes, as well as associated integration services and software from Rand Worldwide, to product developers and manufacturers across North America. Unlike traditional CAD/CAM/CAE/PDM technologies, PLM provides collaborative solutions to define and manage information throughout the complete product lifecycle and across the entire extended enterprise.



Dassault Systèmes
9, quai Marcel Dassault, BP310
92156 Suresnes Cedex France
Tel: 33 (1) 40 99 40 99



CATIA®, DELMIA®, ENOVIA® and SIMULIA® are registered trademarks of Dassault Systèmes or its subsidiaries in the US and/or other countries.

Images courtesy of C&D Zodiac.
© Copyright Dassault Systèmes 2008.
All Rights Reserved.
RF_F_HLO4Z_EN_200802

For more information or to contact a sales representative, visit www.3ds.com/contacts